



Thermo Scientific Q Exactive HF-X Hybrid Quadrupole-Orbitrap MS System

- Scan speed up to 40 Hz with ultra-high-field Thermo Scientific™ Orbitrap™ mass analyzer technology
- Resolution of up to 240,000 (FWHM) at m/z 200
- High Capacity Transfer Tube (HCTT) and electrodynamic ion funnel for improved sensitivity
- Advanced Quadrupole Technology (AQT) for superior precursor isolation
- Advanced Active Beam Guide (AABG) for greater sensitivity and maximum robustness
- New Data Dependent Acquisition (DDA) strategy for bottom-up and top-down proteomics analysis
- Dynamic retention time adjustment in PRM for superior targeted quantitation
- Accelerated Higher-Energy Collisional Dissociation (aHCD) capabilities
- BioPharma option for enhanced analysis of intact proteins, protein-protein complexes, mAb subunits, and intact mAb. Includes Intact Protein Mode and High Mass Range (HMR) mode.

The Thermo Scientific™ Q Exactive™ HF-X Hybrid Quadrupole-Orbitrap™ mass spectrometer combines a high-resolution, accurate-mass (HRAM) ultra-high-field Orbitrap mass analyzer, high capacity transfer tube with electrodynamic ion funnel and high performance quadrupole precursor ion selection to deliver unsurpassed speed and first class sensitivity.

The Q Exactive HF-X MS takes identification and quantitation to an unmatched level, making it possible to identify, quantify, and confirm in a single analysis with a single instrument.

The Q Exactive HF-X MS provides best-in-class performance in peptides, proteins, and small molecule applications. Accelerated Higher Energy Collisional Dissociation (aHCD) allows for MS/MS acquisition up to 40Hz. Advanced Quadrupole Technology (AQT) optimizes precursor ion selection and transmission, improving

quantitation of low-abundant ions in the most complex matrices. Sophisticated Parallel Reaction Monitoring and Data-Independent Acquisition (DIA) methods provide reproducible quantitation results while delivering complete qualitative confidence. 240,000 maximum resolving power at m/z 200 (FWHM), ensures more confident structural confirmation in biopharma and omics applications. The new BioPharma option adds superior capabilities when it comes to the analysis of native proteins or protein complexes and their subunits (top/middle-down), and peptide mapping characterization.

Hardware specification

Thermo Scientific Ion Max API Source

- H-ESI II probe with dual desolvation zone technology
- Enhanced sensitivity and ruggedness
- Sweep gas to reduce chemical noise
- 60° interchangeable ion probe orientation

High-capacity ion transfer tube

- The High Capacity ion Transfer Tube (HCTT) increases ion flux into the vacuum system for improved sensitivity and desolvation
- Vent-free maintenance

Electrodynamic ion funnel

- Electrodynamic Ion Funnel (EDIF), a radio frequency device, efficiently captures ions as they leave the HCTT
- Automatic tuning results in broad transmission curves, reduces ion losses and leads to increased sensitivity

Quadrupole mass filter

- Advanced Quadrupole Technology (AQT) featuring a segmented Thermo Scientific™ HyperQuad™ mass filter provides increased ion transmission and superior isolation window shape
- Variable precursor ion isolation width selection from 0.4 Da to full mass range

Vacuum system

- Differentially pumped vacuum system with final vacuum $<1 \times 10^{-9}$ mbar
- Two split-flow turbomolecular pumps and two rotary vane pumps
- Seven vacuum regions

Orbitrap mass analyzer

- Nitrogen-filled C-Trap
- Highly efficient ion transfer to the Orbitrap mass analyzer
- Straight multipole collision cell for HCD experiments
- Ultra-high-field Orbitrap mass analyzer with 5 kV central electrode voltage
- Low-noise image current preamplifier
- 16-bit signal digitalization

Data Acquisition

- Ultra fast real-time data acquisition and instrument control system
- Fully automated system calibration via instrument control software
- Automatic Gain Control (AGC) support

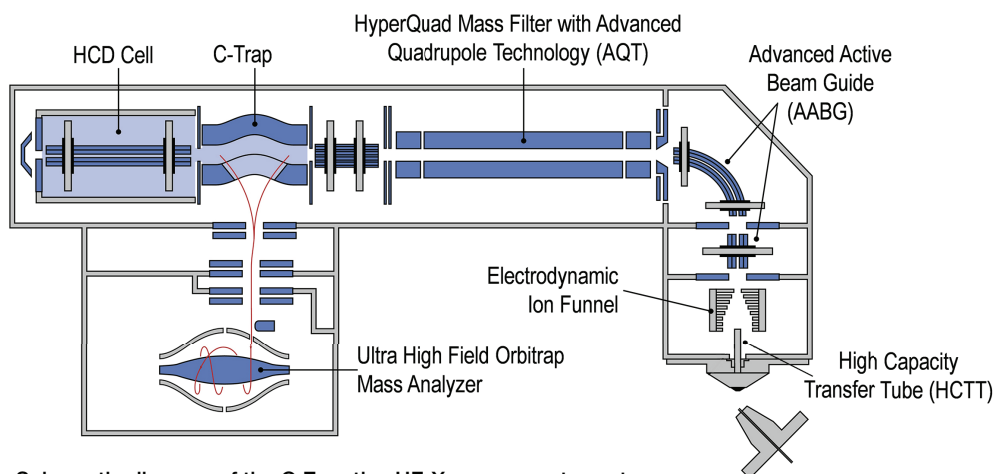

Schematic diagram of the Q Exactive HF-X mass spectrometer

Performance Characteristics

Resolution	240,000 at m/z 200
Mass range	50 to 6,000 m/z (up to 8,000 m/z) **
Scan rate*	Up to 40 Hz at resolution setting of 7,500 at m/z 200
Mass accuracy*	Internal: < 1 ppm RMS External: < 3 ppm RMS
Sensitivity	MS/MS: 100 fg reserpine on column S/N 150:1 SIM: 50 fg reserpine on column S/N 150:1
Dynamic range	> 5,000:1
Polarity switching	One full cycle in < 1 sec (one full positive mode scan and one full negative mode scan at a resolution setting of 60,000)
Multiplexity	Up to 10 precursors/scan
Analog inputs	One (1) analog input (0–1 V) One (1) analog (0–10 V)

*Under defined conditions

** With BioPharma option

Options

- BioPharma Option: Enhanced analysis of large molecules including intact proteins and large complexes sprayed under native conditions. Includes High Mass Range mode with mass detection up to m/z 8,000.
- Thermo Scientific™ EASY-Spray™ source offers state-of-the-art performance from an effortless and robust plug-and-spray solution
- Thermo Scientific™ Nanospray Flex™ ion source offers ultimate nanospray flexibility with excellent spray stability and efficiency for the widest range of nanoflow columns
- ESI probe compatible with liquid flow rates of <1 $\mu\text{L}/\text{min}$ to 1 mL/min without splitting
- Metal needle kits for high and low-flow analyses
- APCI/APPI source compatible with liquid flow rates of 50 $\mu\text{L}/\text{min}$ to 2 mL/min without splitting

Software features

Data system

- High-performance PC with Intel® microprocessor
- High-resolution LCD color monitor
- Microsoft Windows 7® operating system
- Microsoft Office® software package
- Thermo Scientific™ Xcalibur™ instrument control and data processing software
- Workflow-based Exactive Series Method Editor and Tune Software

Operation modes

- Full Scan with high-resolution, accurate-mass detection
- Selected Ion Monitoring (SIM) Scan with high resolution/accurate mass detection
- Parallel Reaction Monitoring (PRM) Scan for improved screening and quantitative confidence
- Data-Independent Acquisition (DIA) for unbiased identification and quantitative analysis
- All Ion Fragmentation (AIF) Scan in the HCD cell with high-resolution, accurate-mass detection
- In-source fragmentation
- Positive/Negative Ion Mode switching on chromatographic timescale
- On-the-fly data dependent decision making
- Timed SIM scan for scheduled data acquisition of the targets of interest



Q Exactive HF-X mass spectrometer with H-ESI II ion source and Thermo Scientific™ Vanquish™ UHPLC System

Exclusive technologies

- Automatic Gain Control (AGC) ensures that the Orbitrap mass analyzer is filled with the optimum number of ions for all scans
- High-performance HCD cell for highest quality MS/MS data
- Collision energy profiling using different collision energies for dissociation and fragmentation
- Advanced signal processing
- Interleaved operation
- Spectrum multiplexing for detection of up to 10 precursor ions in the Orbitrap mass analyzer simultaneously

Installation requirements

Power

- 2 x 230 V_{AC} ± 10% single phase, 15 A, 50/60 Hz with earth ground for the instrument
- 120 or 230 V_{AC} single phase with earth ground for the data system

Gas

Nitrogen

- Source gas (minimum requirement): High-purity nitrogen gas supply (99% pure at 800 ± 30 kPa ((8.0 ± 0.3 bar, 116 ± 4 psi))
- HCD gas (recommended): High-purity nitrogen gas supply (99.999% pure at 800 ± 30 kPa (8 ± 0.3 bar))

Environment

- System averages 2,800 W (~10,000 Btu/h) output when considering air conditioning needs
- Operating environment must be 15–26 °C (59–78 °F) with relative humidity between 40–70% with no condensation
- Designed for indoor use at an altitude of up to 2000 m (6500 ft) above sea level.

Weight

- Q Exactive HF-X mass spectrometer: 182 kg (400 pounds) without forevacuum pumps
- Forevacuum pumps: 100 kg (220 pounds)
- Auxiliary vacuum pump: 17 kg (37 lbs)

Dimensions

- Q Exactive HF-X mass spectrometer:
(h × d × w) 950 × 830 × 910 mm
(37 × 33 × 36 inches)

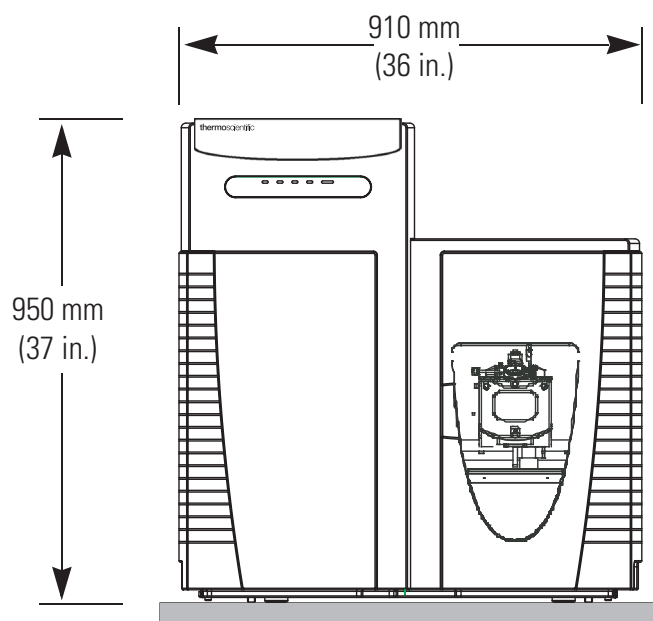

Find out more at thermofisher.com/QExactiveHFX